

AMERICAN AVK RESILIENT SEATED GATE VALVE
250 PSI, INTERNATIONAL (NRS)
ANSI B16.1 Class 125 Flanged x Flanged Ends - Valve Sizes 3" - 6"

716/FFN
FLxFL

Use:

For water and neutral liquids to maximum 160°F.

Tests:

Hydraulic test to AWWA C509:

Shell Test: 500 PSI

Seat Test: 250 PSI

Operating Torque Test

Standard Materials:

| | |
|---|---|
| Body, Bonnet, Gland Flange | Ductile iron ASTM A536 |
| Coating | Electrostatically applied fusion-bonded epoxy-resin Meets or exceeds AWWA C550 |
| Wrench Nut | Ductile iron ASTM A536 - painted black for open left, red for open right. |
| Stem | Standard: Stainless Steel, ASTM A582 |
| Wedge | Ductile iron ASTM A536 encapsulated with EPDM-rubber compound |
| Wedge Nut, Thrust Collar | Bronze |
| Bonnet Bolts, Gland Bolts | Zinc Plated Steel sealed with hot melt |
| Bonnet Gasket Wiper Ring, O-Ring Stem Seals, O-Ring Gland Seal | ASTM D2000 Buna "N" nitrile rubber |

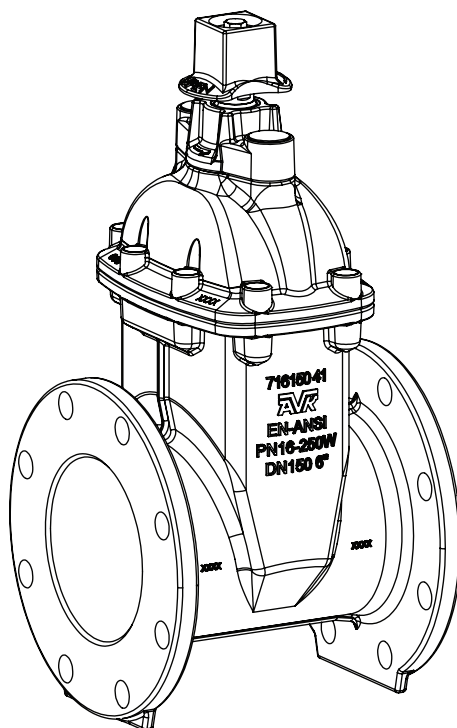

AMERICAN AVK RESILIENT SEATED GATE VALVE
250 PSI, INTERNATIONAL (NRS)
ANSI B16.1 Class 125 Flanged x Flanged Ends - Valve Sizes 3" - 6"

716/FFN
FLxFL

Component List:

- | | | |
|--------------------|------------------------------|--------------------|
| 217. Bonnet | 228. Gland Flange | 233. NRS Stem |
| 218. Bonnet Gasket | 229. Gland O-Ring | 234. Thrust Collar |
| 219. Body | 230. Upper Stem Seal O-Rings | 237. Wedge |
| 225. Wrench Nut | 231. Stem Seal Bushing | |
| 226. Wiper Ring | 232. Lower Stem Seal O-Ring | |

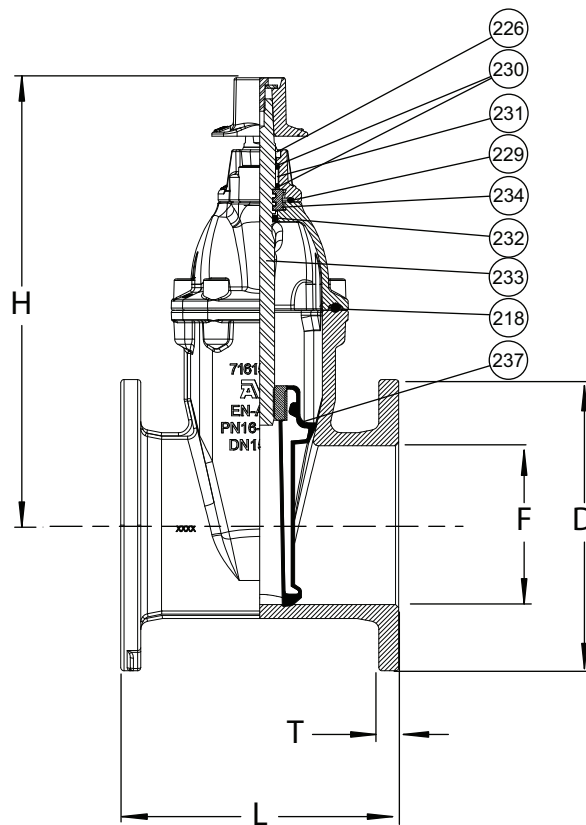
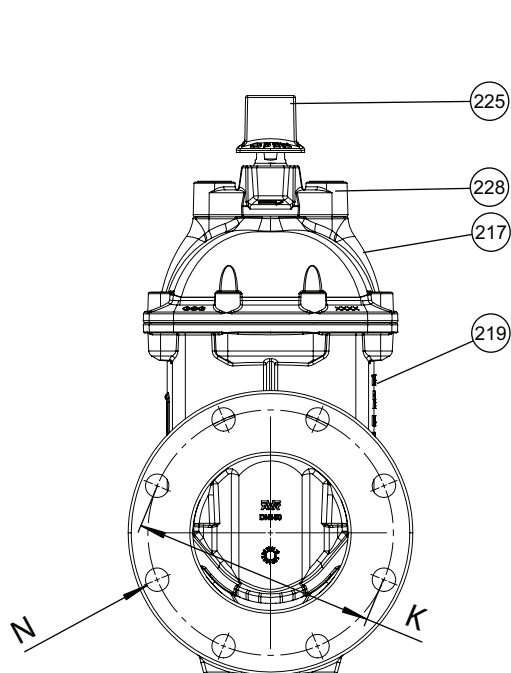

| Ref No. | Size | D | F | H | K | L | N | T | Flange Holes | Turns to Open | Wt. Lbs. |
|-------------|------|--------|-------|--------|-------|--------|-------|-------|--------------|---------------|----------|
| 716-080-FFN | 3" | 7.50" | 3.00" | 11.70" | 6.00" | 8.00" | 0.79" | 0.75" | 4 | 16 | 39 |
| 716-100-FFN | 4" | 9.00" | 4.00" | 12.96" | 7.50" | 9.00" | 0.79" | 0.75" | 8 | 21 | 54 |
| 716-150-FFN | 6" | 11.00" | 6.00" | 16.90" | 9.50" | 10.50" | 0.90" | 0.75" | 8 | 26 | 86 |

