

AMERICAN AVK RESILIENT SEATED GATE VALVE
250 PSI, Tested to AWWA C515 (NRS)
Mechanical Joint Ends to AWWA C111 by
Flanged Ends to ASME B16.42 Class 150 - Valve Size 36"

55/MFN36
MJxFL BYPASS

Use:

For water and neutral liquids to maximum 160°F.

Tests:

Hydraulic test to AWWA C515:

Shell Test: 500 PSI

Seat Test: 250 PSI

Operating Torque Test

Optional Materials:

Stem Bronze

Bonnet Bolts Stainless Steel - 316
 bolt sealed with hot melt

Gland Bolts, Stainless Steel - 316

Options:

Handwheel, Electric Actuator, Bevel Gear, Spur Gear

Approvals:

Certified to: ANSI/NSF 61, ANSI/NSF 372



Standard Materials:

Body, Bonnet, Ductile iron ASTM A536
 Gland Flange, Elbow

Coating Electrostatically applied fusion-
 bonded epoxy-resin
 Meets or exceeds AWWA C550

Stem Standard: Stainless steel ASTM A276

Wedge Ductile iron ASTM A536
 encapsulated with EPDM-rubber
 compound

Wedge Nut, Bronze
 Thrust Collar

Bonnet Bolts, Stainless Steel -304 sealed with hot
 Gland Bolts melt

Bonnet Gasket, ASTM D2000 Buna "N" nitrile
 Wiper Ring, rubber
 O-Ring Stem Seals,
 O-Ring Gland Seal

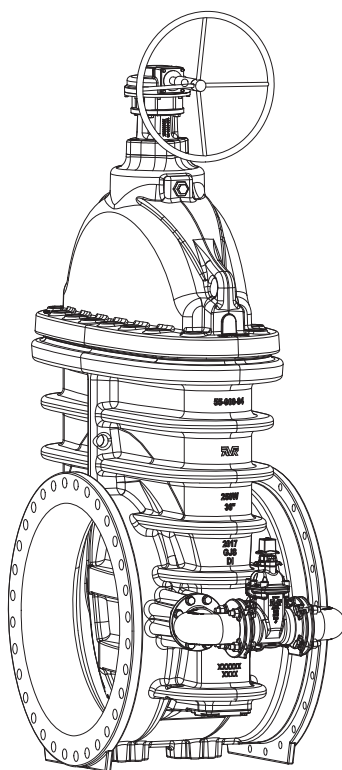

AMERICAN AVK RESILIENT SEATED GATE VALVE
250 PSI, Tested to AWWA C515 (NRS)
Mechanical Joint Ends to AWWA C111 by
Flanged Ends to ASME B16.42 Class 150 - Valve Size 36"

55/MFN36
MJxFL BYPASS

Component List:

- | | | |
|------------------------------|-------------------------|----------------------------------------------------|
| 216. Bonnet Bolts | 233. Stem Rod | 260. Cover Plate Bolt |
| 217. Bonnet | 234. Thrust Collar | 261. Elbow Bolt |
| 218. Bonnet Gasket | 237. Wedge | 262. Elbow Washer |
| 219. Body | 247. Key | 263. Elbow Gasket |
| 226. Wiper Ring | 251. Elbow | 264. Upper Stem Seal O-Rings
(36 Inch Valves) |
| 227. Gland Flange Bolt | 252. Shoe | 265. Gland Bolt O-ring |
| 228. Gland Flange | 255. Stem Bearing | 266. Thrust Collar Bolt |
| 229. Gland O-Ring | 256. Wedge Slotted Pin | 267. Thrust Collar Washer |
| 230. Upper Stem Seal O-Rings | 257. Cover Plate O-ring | 268. Air Bleeder Fittings |
| 231. Stem Seal Bushing | 258. Cover Plate | |
| 232. Lower Stem Seal O-Ring | 259. Cover Plate Washer | |

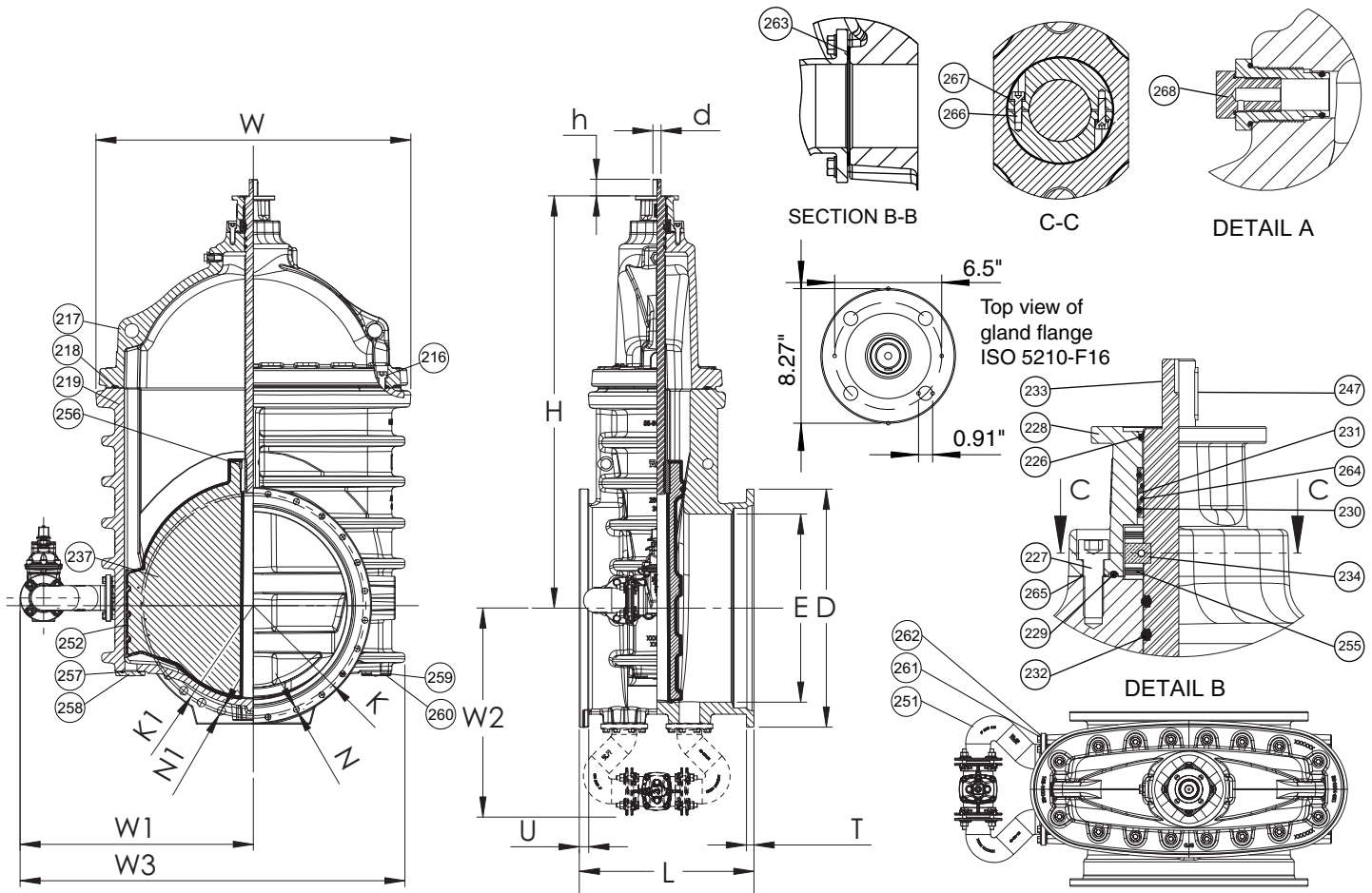

Ref. nos	Size	D	E	d	H	h	K	K1	L	N/N1	T	U	W	W1	W2	W3	FL-Holes MJ/FL	Turns to open	Wt. Lbs.
55-900-MFN-BP	36"	46.00"	36.37"	2.00"	79.70"	4.00"	43.75"	42.80"	33.75"	1.13"/1.63"	1.45"	1.83"	61.34"	45.27"	41.61"	75.88"	24/32	70	8572

Add 86 Lbs. for bevel gearing w/ handwheel, add 120 Lbs. for spur gearing w/ handwheel
 See Bevel & Spur Gearing datasheets for overall dimensions

